

SPECIFICATION

A: MATERIAL:

- 1.BODY: PC
- 2.Pin: Cu PLATED Ni
- 3.TINPLATE: SPTe
- 4.COVER: PC

B: CHARACTERISTICS:

- 1.RATING: 2.5A 250V~(C-ULus, ENEC & CCC & KC)
- 2.INSULATION RESISTANCE:100MΩ MIN,AT 500VDC
- 3.ELECTRIC STRENGTH : 3000 VAC/1MIN,LEAKAGE CURRENT UNDER 0.5mA

C: APPROVALS: C-ULus, ENEC & CCC & KC

D: MATERIAL USED MUST BE COMPLY WITH HQI-0010

E: CAN MEET RoHS

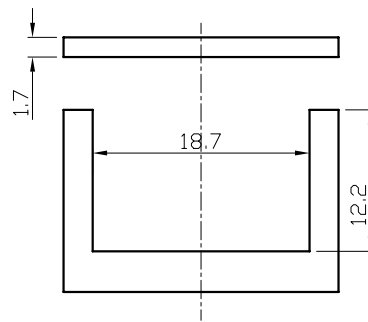

PANEL CUT-OUT

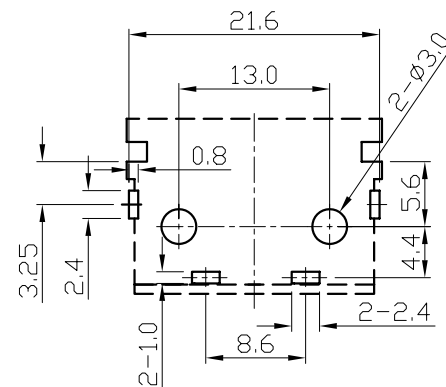
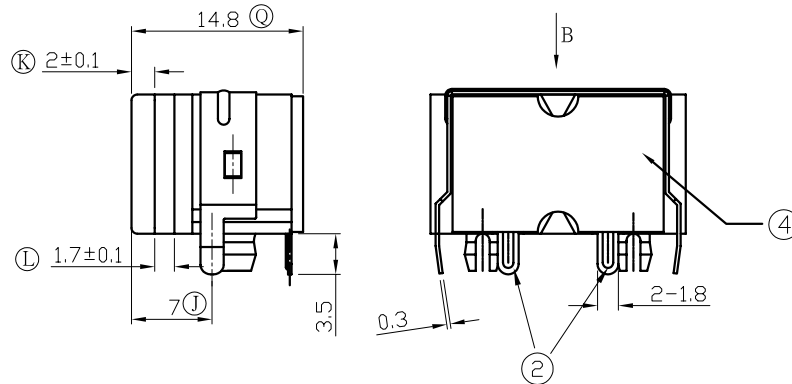
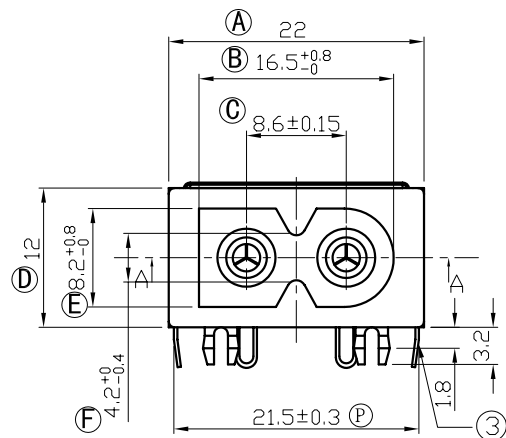

PCB LAYOUT

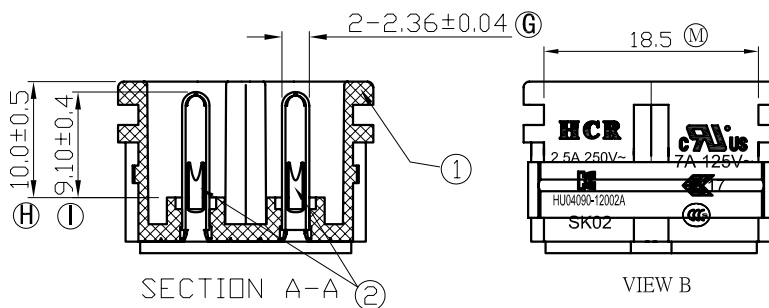
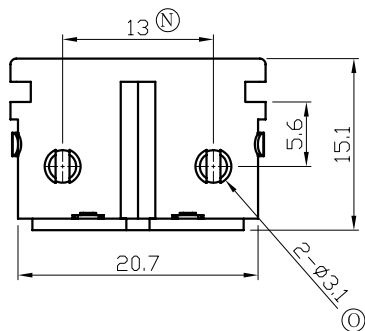

SECTION A-A

VIEW B

| | |
|--|-------|
| TOLERANCES UNLESS OTHERWISE 未指定容許差尺寸之公差 | |
| BASIC DIMENSIONS TOLERANCES | |
| UP TO 10 (10以下) | ±0.15 |
| ABOVE 10 TO 30(10-30) | ±0.3 |
| ABOVE 30 TO 100(30-100) | ±0.5 |
| ANGULAR DIMENSIONS(角度) | ±5° |
| DIMENSION UNIT | mm |

東莞市華之力電子有限公司 DONGGUAN HCR ELECTRONICS CO., LTD.

| | | | | | | | | | | | | | |
|----|------------|----------------------|----------|---------|-------------------|----------------|------------|------------|----------------|--------------|------------------------|---------------|-------------------|
| 2 | | | | | 核准 APPROVED BY | AaronJin | 日期 DATE | 20130909 | 投影法 PROJECT | | 機型 PART NAME | INLET SOCKET | |
| 1 | | | | | 校對 CHECKED BY | RZTang | 日期 DATE | 20130909 | 比例 SCALE | 1:1 | 型號 PART NO | SK02 | |
| 0 | 2013/09/09 | 1.新制訂 | A0 | Lampang | RZTang | 繪圖 DRAWN BY | Lampang | 日期 DATE | 20130909 | 路徑 DWG NO | E:\成品圖 VSK02\820189 | 料號 ITEM NO | SK02-4301222423BT |
| NO | DATE | REVISION DESCRIPTION | REVISION | DRAWN | APPROVED | | | | | | | | |